

DynaPath 

# A-SERIES BED MILLS

3-Axis CNC for Job Shops, Tool Rooms, and General Production

Featuring Semi-Automatic + Conversational DXF + G-Code Programming



DynaPath 

# A-Series Bed Mills are offered in two styles:

## ATC HEAD

*The standard milling center for production*



- 10 HP Spindle up to 8000 RPM
- Automatic Tool Changer, up to 16 tools
- Spindle Orientation and Rigid Tapping

## D5 CONSOLE

12.1" Industrial touchscreen LCD Operating console with alphanumeric input panel and ATC + CNC operation.

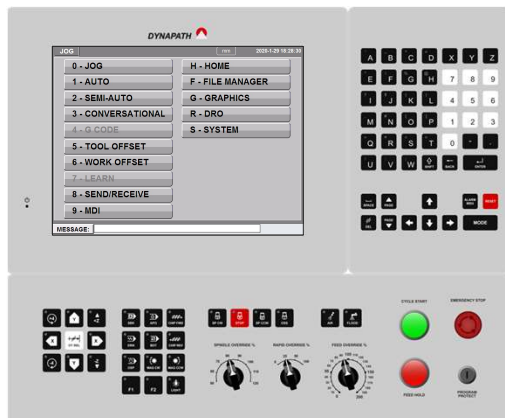

## QUILL HEAD

*For manual work, tool rooms, and small lot jobs*



- 5 HP Spindle up to 5000 RPM with High/Low Gear
- Manual Quill with linear encoder, up to 127mm (5") of travel, in addition to CNC Z-axis

## D1 CONSOLE

12.1" Industrial touchscreen LCD Operating console for basic CNC operation.



# DynaPath WinDelta® Control System

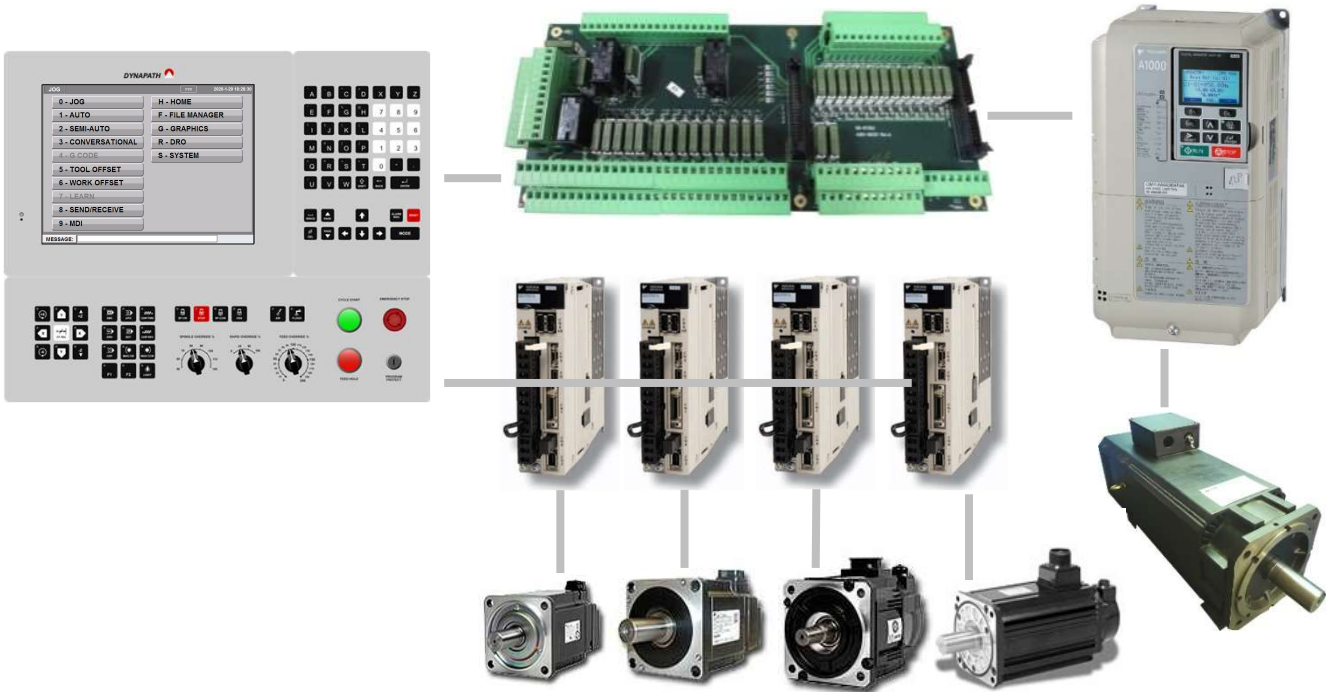

## CNC Hardware Specifications

<p><b>Control Storage</b></p> <p><b>Serial Ports</b></p> <p><b>Networking</b></p> <p><b>Device Inputs</b></p> <p><b>Display</b></p> <p><b>Operating Panel</b></p>	<ul style="list-style-type: none"> <li>• DynaPath WinDelta CNC</li> <li>• 8 GB SSD</li> <li>• RS232, RS422/RS485</li> <li>• T10/T100 Ethernet Port</li> <li>• 1x PS/2, 2x USB 2.0</li> <li>• 12.1"/15.6" Industrial LCD Touch Display</li> <li>• 400 cd/m<sup>2</sup> Luminance</li> <li>• MDI 1<sup>st</sup> Panel + 2<sup>nd</sup> Panel</li> </ul>	<p><b>Handwheel Axis Control</b></p> <p><b>Standard I/O</b></p> <p><b>Expansion I/O</b></p> <p><b>Power Input</b></p>	<ul style="list-style-type: none"> <li>• 8-Function Remote Jog Unit (MPG)</li> <li>• 4-axis simultaneous</li> <li>• 59 DI/33 DO</li> <li>• 6-channel D/A</li> <li>• *5 Channel A/D Optional</li> <li>• 2x Remote I/O ports (64I/64O each)</li> <li>• 24 VDC</li> </ul>
---	---	---	--

## Environmental Specifications

<p><b>Operating Temp</b></p> <p><b>Storage Temp</b></p> <p><b>Operating Humidity</b></p>	<ul style="list-style-type: none"> <li>• 0 to 50 °C (0 to 122 °F)</li> <li>• -20 to 60 °C (-4 to 140 °F)</li> <li>• 5% to 85% RH, non-condensing</li> </ul>	<p><b>Vibration</b></p> <p><b>EMI/EMS</b></p>	<ul style="list-style-type: none"> <li>• 16.7 Hz: acceleration of 1.5G</li> <li>• 10 to 57 Hz: amplitude of 0.075 mm</li> <li>• 57 to 150 Hz: acceleration of 1G</li> <li>• 1.5 kV CE certified</li> </ul>
--	---	---	--

# Advanced Path Planning with Look Ahead and Feed Forward

**Path Smoothing** algorithms provide precision control and curvature control. The result is the optimal tool path for speed and precision.

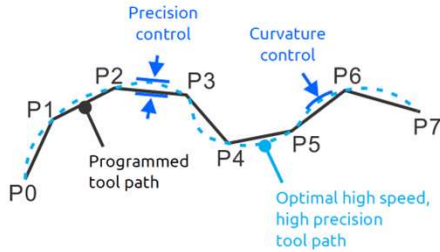

**Look Ahead** anticipates upcoming programmed motion, and plans the optimal trajectory in real time up to 1000 blocks.

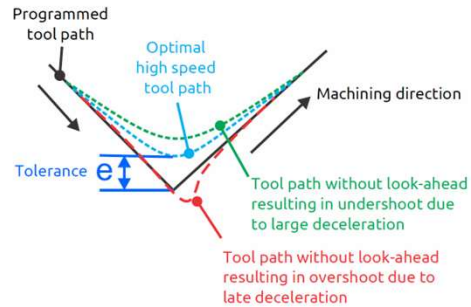

**Smart Interpolation** ensures machining accuracy by performing acceleration and deceleration before path interpolation.

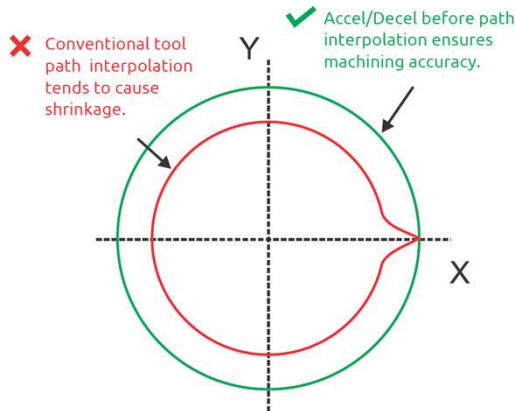

**Jerk Reduction** is performed by using trapezoidal or S-curve acceleration and deceleration, allowing smoother motion, higher machining speeds, and helps protect against machine wear.

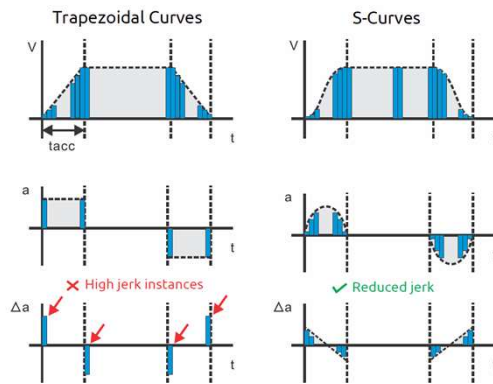

## Without Feed Forward and Friction Compensation

XY and Z axes motion accuracy is prone to in correctable position errors, as demonstrated in the following plots on a circular tool path of 28.3mm diameter, at 8 m/min feed rate. In this case the final trajectory has a maximum position error exceeding 20  $\mu\text{m}$  and more than 6  $\mu\text{m}$  reversal spikes are presented.

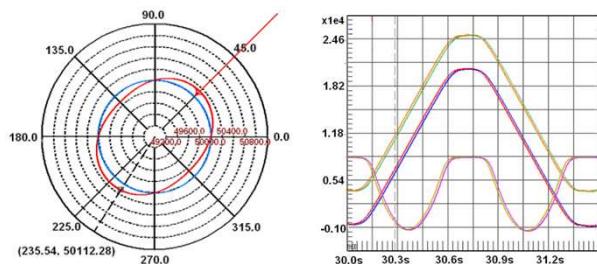

## With Feed Forward and Friction Compensation

XY and Z axes motion accuracy is greatly increased, as demonstrated in the following plots on a circular tool path of 28.3 mm diameter, at 8 m/min feed rate. The final trajectory has a maximum position error within 5  $\mu\text{m}$  and the reversal spikes are less than 2  $\mu\text{m}$ .

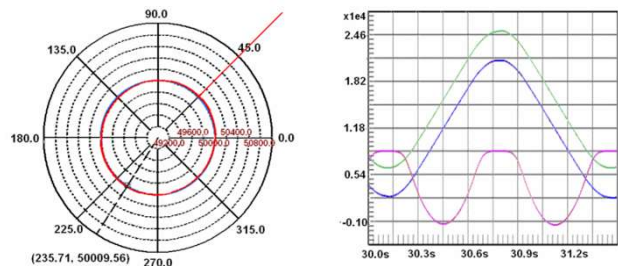



WinDelta® CNC is the most versatile control for all your many operations:

## Semi-Automatic + Conversational Programming + G-Code

### SEMI-AUTOMATIC OPERATION

For quick and simple jobs, or work requiring the skilled hands of an experienced machinist, **Semi-Automatic Operation** functionality offers operators the most **friendly and familiar** way to do the job.



### CONVERSATIONAL PROGRAMMING

For general parts and jobs, the **Conversational Editor with DXF Import** enables any operator to generate part programs without writing G-Code, oftentimes faster than it takes to set up for the part.

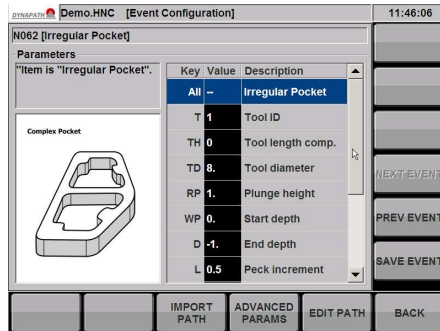

### CAD/CAM G-CODE

For CAD/CAM users, simply post-process to standard **ISO/EIA G-Code**, then send the program via **USB or networked file transfer** to the control, and fully leverage the power of CNC production.

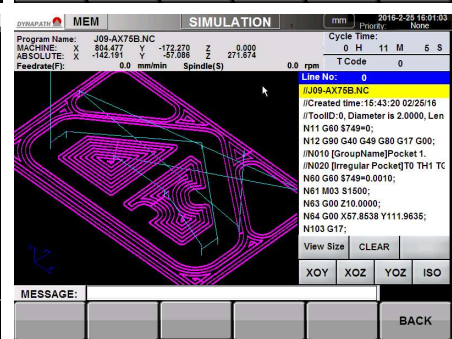
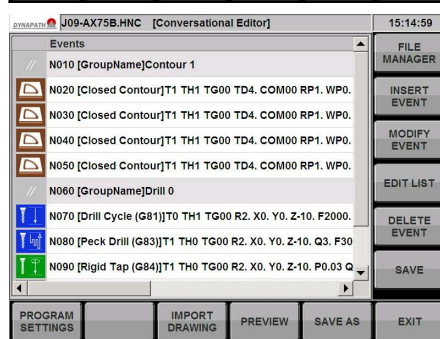
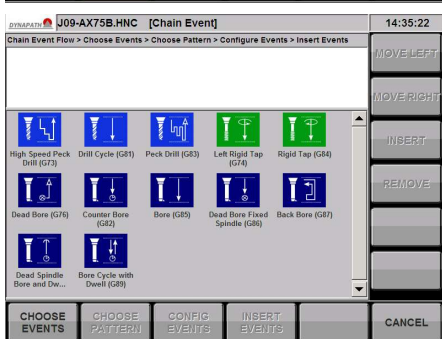
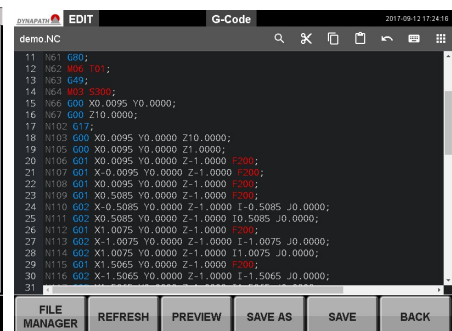
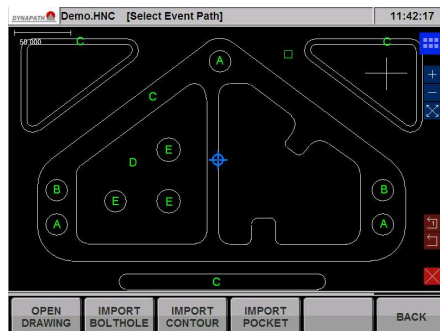
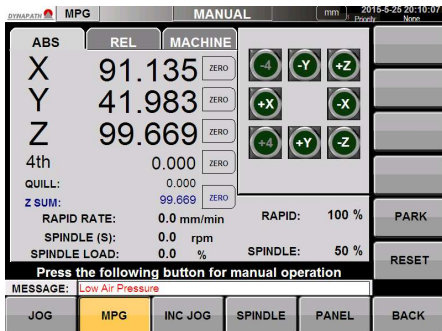
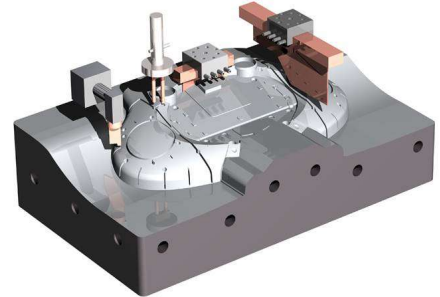

# DynaPath WinDelta® Programming

## Conversational Programming + DXF Import + G-Code Editing

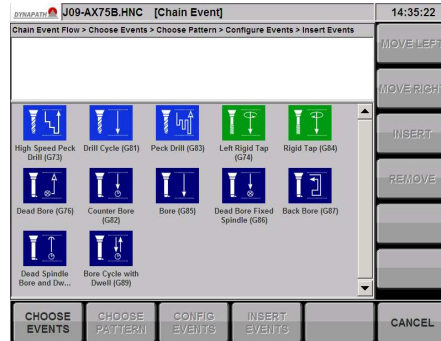
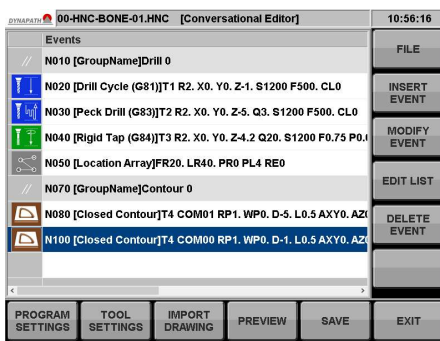

**Conversational Event Based Programming** allows making part programs by simply choosing machining events and configuring its parameters, without having to write G-Code.

**Built-in Events** include standard drill, bore, tap, contour, pocket, helix, pattern, setup, and auxiliary events.

**Smart Profile Editor** allows quick and easy path creation and assists with geometric calculations.

**Conversational Graphics** convey detailed information about event parameters using graphical illustrations to assist with data entry.

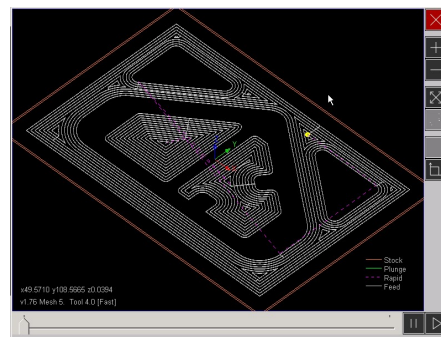
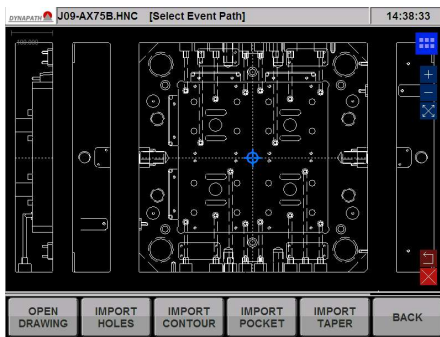
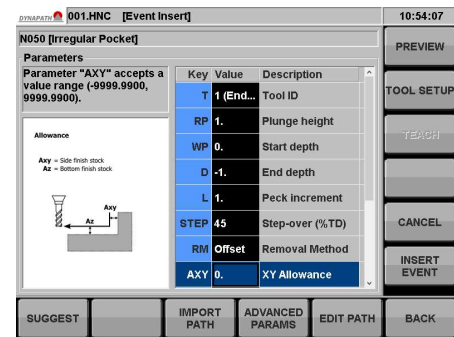
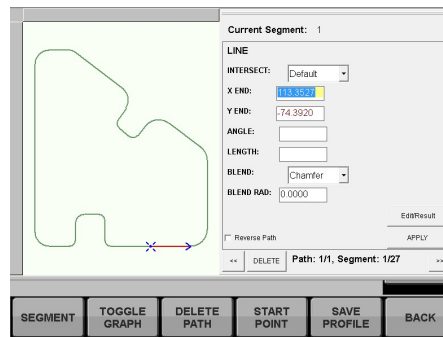

**DXF Drawing Import** allows direct geometry import from CAD drawings via an intuitive, touchscreen interface, saving programming time and reducing errors.

**Preview Simulation** allows visual inspection of generated tool paths and final dimensions.

**G-Code Editor** enables ISO/EIA G-Code editing for writing standard G-Code part programs or to fine tune CAD/CAM posts.

**File Manager and Server** allows USB file transfer and Networked FTP file management of all part programs and drawings on the control.

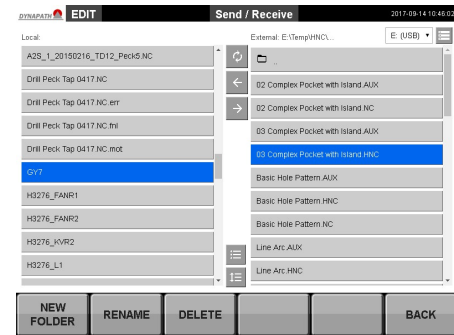
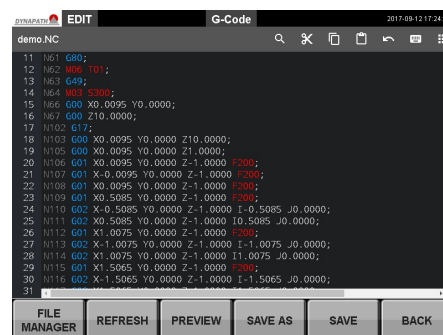

**A-SERIES BED MILLS - SIZE AND SPECIFICATIONS**

MODEL	A1	A2	A2-T	A3	A3-T
TYPE	Bed Mill	Bed Mill		Bed Mill	
SPINDLE TAPER	NST40/CAT40	NST40/CAT40		NST40/CAT40	
SPINDLE RPM	70-5000 RPM	70-5000 RPM	70-8000 RPM *Dual Winding	70-5000 RPM	60-8000 RPM *Dual Winding
SPINDLE MOTOR	5 HP Belt Drive	5 HP Belt Drive	7.5 kW (10HP) Belt Drive	5 HP Belt Drive	7.5 kW (10HP) Belt Drive
TOOL CHANGER	---	---	16-Tool Carousel	---	16-Tool Carousel
TRAVEL X	710 mm (27.95")	830 mm (32.67")		1000 mm (39.37")	
TRAVEL Y	400 mm (15.74")	500 mm (19.68")		500 mm (19.68")	
TRAVEL Z	500 mm (19.68")	610 mm (24.01")	590 mm (23.22")	610 mm (24.01")	520 mm (20.47")
SPINDLE TO TABLE	100-600 mm (3.94"-23.62")	100-710 mm (3.94"-27.95")	100-690 mm (3.94"-27.16")	100-710 mm (3.94"-27.95")	100-620 mm (3.94"-24.40")
TOOL TO COLUMN	420 mm (16.53")				
QUILL TRAVEL	127 mm (5.00")	127 mm (5.00")	---	127 mm (5.00")	---
QUILL DIAMETER	100 mm (3.93")	100 mm (3.93")	---	100 mm (3.93")	---
TABLE LENGTH	1244 mm (48.97")	1370 mm (53.93")		1524 mm (60.00")	
TABLE WIDTH	228 mm (8.97")	254 mm (10")		330 mm (12.99")	
TABLE SLOTS	3 x 65 mm x 16 mm (3 x 2.55" x 5/8")				
AXIS TYPE X/ Y/ Z	Dove/ Dove/ Dove	Dove/ Square/ Square			
MOTORS X/ Y/ Z	0.75/ 0.75/ 0.75 kW Belt Drive				
MAX RAPID SPEED X/ Y/ Z	5000 mm/min (196 IPM)				
POSITIONING ACCURACY	0.02 mm (0.000787")				
REPEAT ACCURACY	0.01 mm (0.000394")				
MACHINE WEIGHT	1790 kg (3938 lbs)	2260 kg (4972 lbs)	2510 kg (5522 lbs)	2410 kg (5302 lbs)	2650 kg (5830 lbs)
DIMENSIONS L x W x H	2270 x 1800 x 2350 mm (90" x 71" x 93")			2730 x 1930 x 2520 mm (108" x 76" x 100")	
FLOOR SPACE L x W x H	2520 x 2590 x 2350 mm (100" x 102" x 99")	3050 x 2840 x 2580 mm (121" x 112" x 102")		3450 x 2840 x 2580 cm (136" x 112" x 102")	
POWER REQUIREMENTS	10 kVA, 3 Phase, 220V		15 kVA, 3 Phase, 220V	10 kVA, 3 Phase, 220V	15 kVA, 3 Phase, 220V

CONTROL SPECIFICATIONS	MACHINE FEATURES	ADDITIONAL OPTIONS
<ul style="list-style-type: none"> <li>• 10.4" /12.1" Touchscreen LCD Display</li> <li>• 4 GB Program Storage</li> <li>• 2 USB, 1 LAN</li> <li>• 3-Axis Synchronous</li> <li>• 4th Axis Rotary Table Optional</li> <li>• DRO Operation</li> <li>• ISO G-Code Motion Interpreter Core</li> <li>• Shop Floor Conversational Programming</li> <li>• DXF Drawing Import via Touch</li> <li>• File Send / Receive thru LAN / USB</li> <li>• FTP Networked File Transfer</li> <li>• Remote Diagnosis &amp; Support</li> <li>• Remote Monitoring and Reporting</li> <li>• 500 Block Look Ahead</li> <li>• Program Retrace, MPG Run</li> </ul>	<ul style="list-style-type: none"> <li>• Z-Axis CNC Controlled Quill</li> <li>• Handheld MPG Jog Unit</li> <li>• Auto Lubrication System</li> <li>• Air/Flood Coolant System</li> <li>• X, Y, Z Axes Ball Screw</li> <li>• Table Guard</li> <li>• Splash Guard</li> <li>• Way Covers</li> <li>• Halogen Work Light</li> <li>• Rigid Tapping (non-Quill head only)</li> <li>• Spindle Orientation (non-Quill head only)</li> </ul>	<ul style="list-style-type: none"> <li>• X,Y,Z Electronic Handwheel</li> <li>• Clamping Kits</li> <li>• 4th Axis Rotary Table</li> </ul>
		

### A1 Dimensions

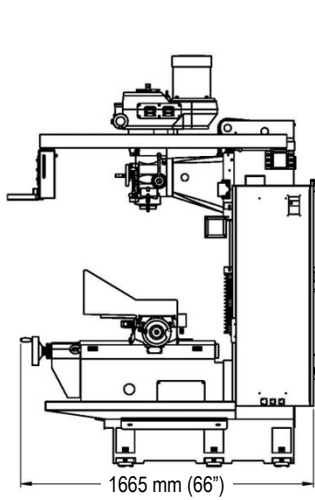
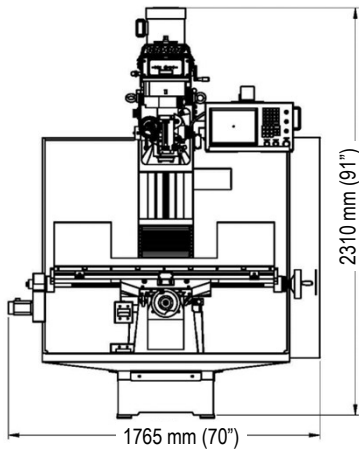
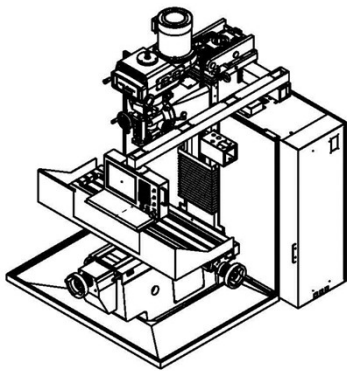

### A2 Dimensions

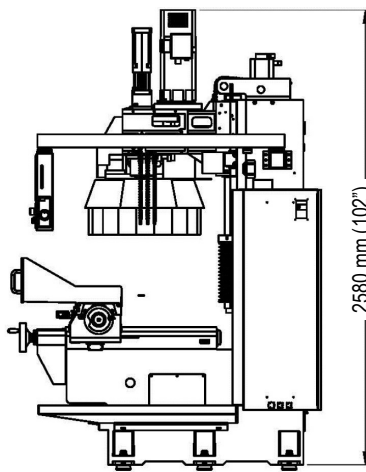
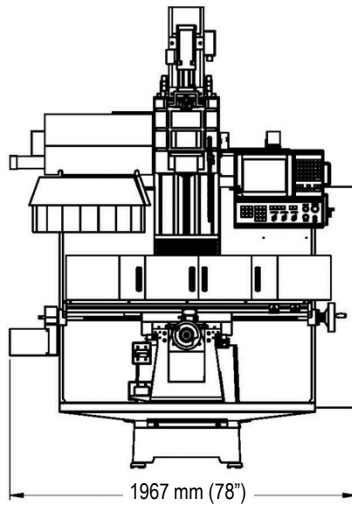
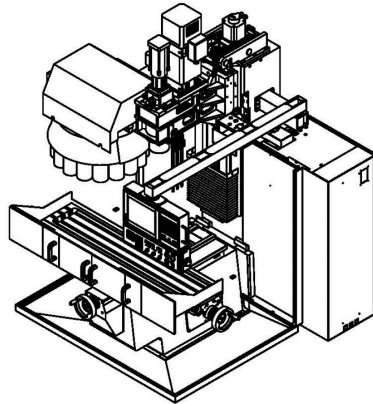

### A3 Dimensions

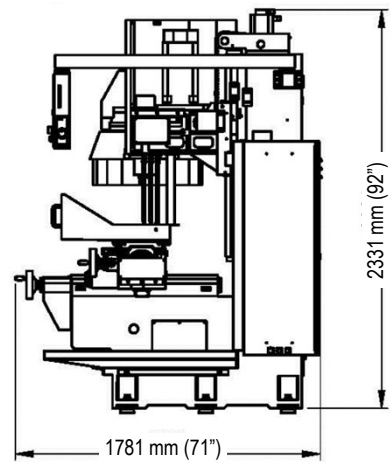
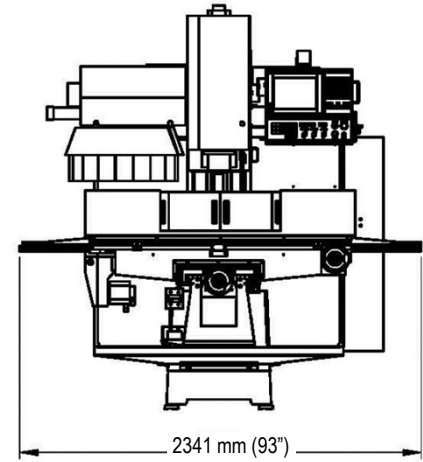
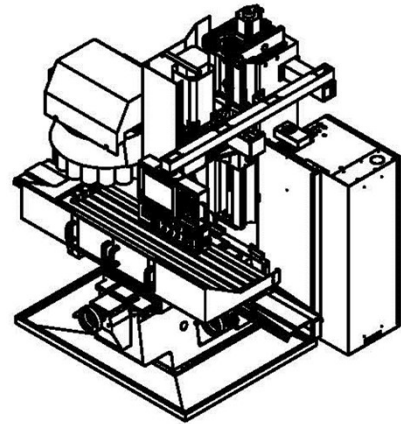





**Your Representative:**

**ZPS-CNC USA, Inc**

**923 Commerce Dr**

**Union Grove, WI 53182**

**<http://www.zpsusa.com>**

**Tel: 262-758-6129**

**Email: [sales@zpsusa.com](mailto:sales@zpsusa.com)**

2022-08

